

## RGB Color Sensor

## KPS-5130PD7C

### Description

•The KPS-5130PD7C Color Sensor Device, consisting of 3-Channel/1Chip (R, G, B) Si photodiode, is a good effective solution to color balance of display backlighting appliances.

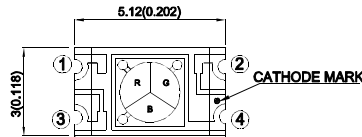

### Features

- \*Lead-free package.
- \*Component in accordance with RoHS.
- \*SMD style package on PCB technology.
- \*Integral Color Filter in Blue, Green, or Red.
- \* Package:1500 pcs/Reel.
- \*Moisture sensitivity level : level 3.
- \* RoHS Compliant.

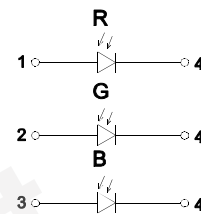
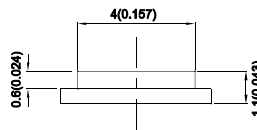

4. Cathode  
1.2.3. Anode

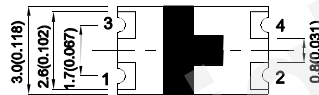

### \*Applications

The devices are suitable for :

- \*colorimetry.
- \*printing process control.
- \*display color correction.

UNIT : MM[INCH]

TOLERANCE : ±0.25[± 0.01"] UNLESS OTHERWISE NOTED.

### \*Absolute Maximum Ratings(Ta=25°C unless otherwise specified)

Parameter	Symbol	Value	Unit
Reverse Voltage	V <sub>R</sub>	10	V
Operating Temperature	Topr	-40~+85	°C
Storage Temperature	Tsto	-40~+85	°C
Soldering Temperature	Tsd	260	°C



**\*Electro-optical Characteristics(Ta=25°C unless otherwise specified)**

Parameter	Symbol	Condition	Value			Unit	
			Min.	Typ	Max.		
Peak Sensitivity Wavelength	$\lambda_p$	Red	-	620	-	nm	
		Green	-	550	-		
		Blue	-	470	-		
Light Current(1)	$I_{L1}$	100Lux <sup>[1]</sup> VR = 5V	Red	-	0.039	-	uA
			Green	-	0.042	-	
			Blue	-	0.022	-	
Light Current(2)	$I_{L2}$	1000Lux <sup>[1]</sup> VR = 5V	Red	-	0.427	-	uA
			Green	-	0.498	-	
			Blue	-	0.262	-	
Diameter of the irradiation sensitive area	D		-	2.0	-	mm	
Irradiation sensitive area per element	A		-	0.85	-	mm <sup>2</sup>	
Photo sensibility of the single color areas	$S_{Max}$	$\lambda_R=620\text{ nm}$ $\lambda_G=550\text{ nm}$ $\lambda_B=470\text{ nm}$	-	0.33 0.25 0.18	-	A/W	
Reverse Dark Current	$I_D$	VR=5V	-	-	10	nA	

Note:

1. White fluorescent light (Color Temperature = 6500K) is used as light source.

Fig.1 Dark Current vs. Ambient Temperature

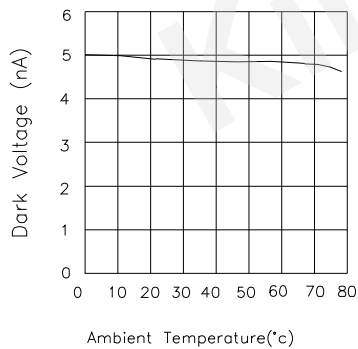

Fig.2 Spectral Response

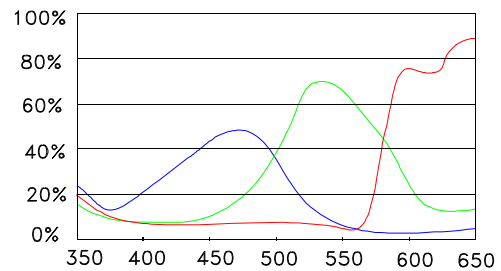
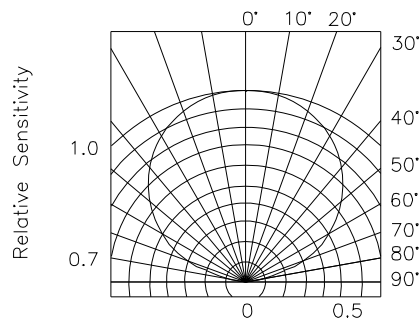

Fig.3 Relative radiant sensitivity vs. Angular displacement



## Typical Electro - Optical Characteristics Curves

Fig.4 R,G,B LED Test vs. Output Photocurrent

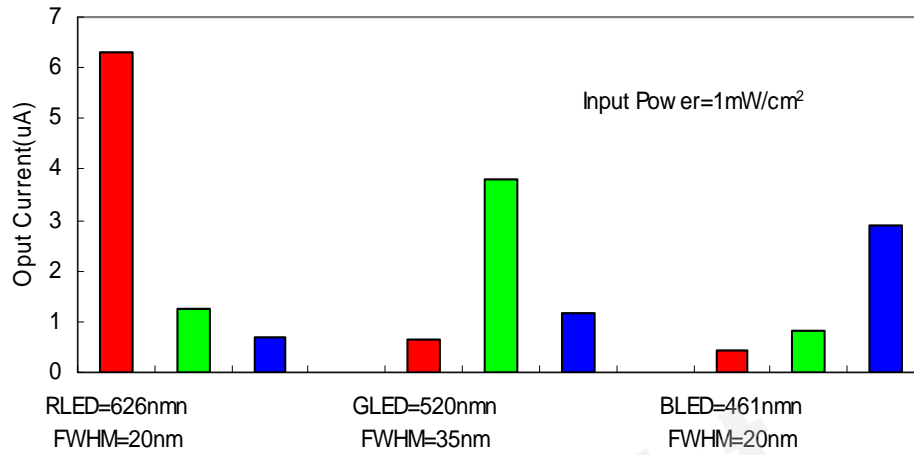
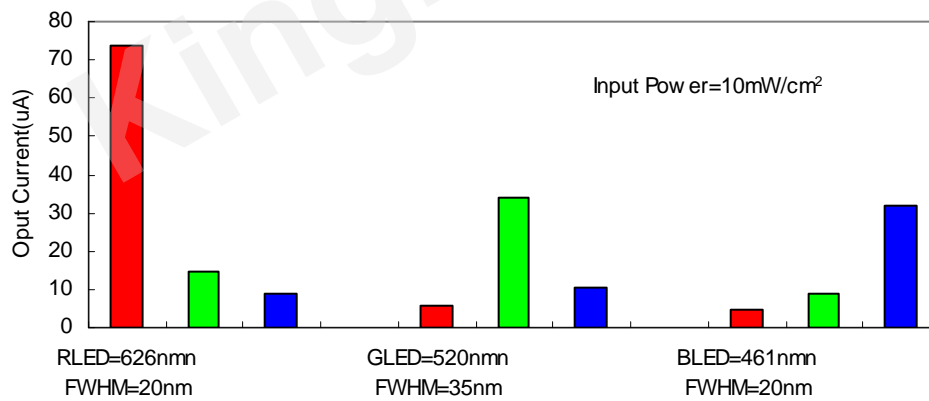
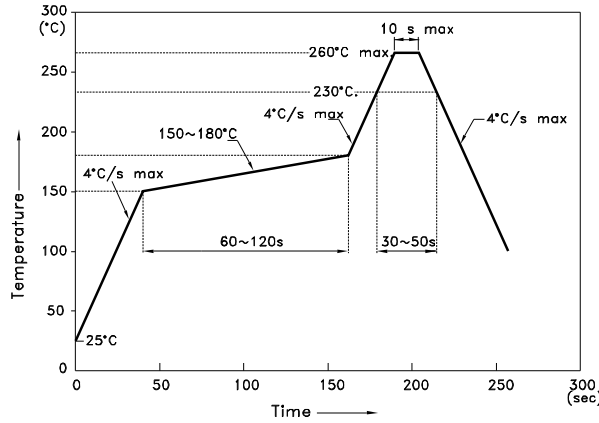

Fig.5 R,G,B LED Test vs. Output Photocurrent



**KPS-5130PD7C**

Reflow Soldering Profile For Lead-free SMT Process.



**NOTES:**

1. We recommend the reflow temperature 245°C(+/-5°C). The maximum soldering temperature should be limited to 260°C.
2. Don't cause stress to the epoxy resin while it is exposed to high temperature.
3. Number of reflow process shall be 2 times or less.

**Recommended Soldering Pattern  
(Units : mm; Tolerance: ± 0.1)**

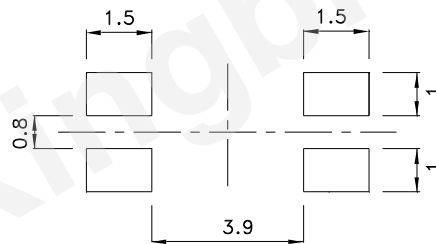

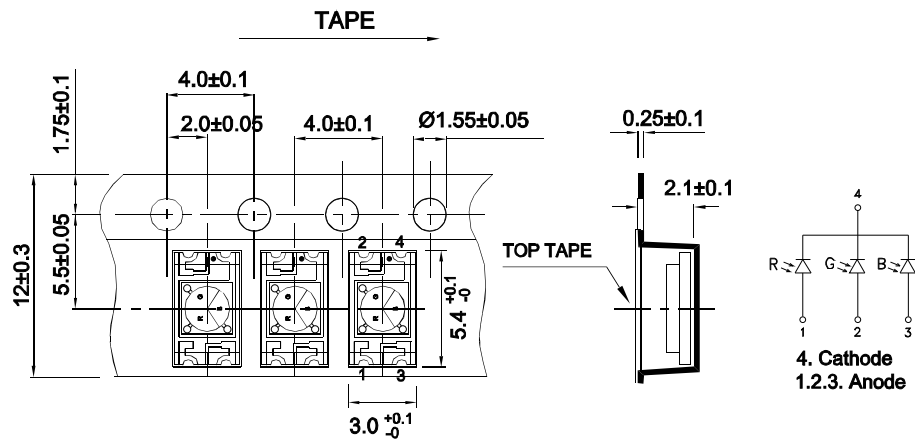

**Tape Specifications  
(Units : mm)**

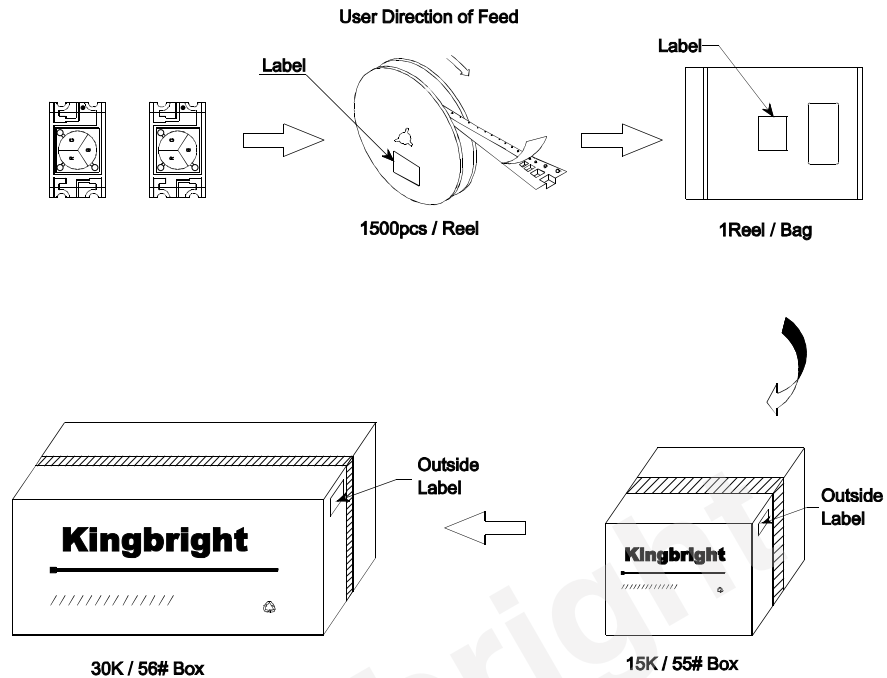

**PACKING & LABEL SPECIFICATIONS**

**KPS-5130PD7C**



<b>Kingbright</b>	
P/NO: KPS-5130xxx	
QTY: 1.500 pcs	Q.C. <span style="border: 1px solid black; border-radius: 50%; padding: 2px;">Q C XX XX XXXX PASSED</span>
S/N: XXXX	
CODE: XXX	
LOT NO:	
	
RoHS Compliant	

**Terms and conditions for the usage of this document**

1. The information included in this document reflects representative usage scenarios and is intended for technical reference only.
2. The part number, type, and specifications mentioned in this document are subject to future change and improvement without notice. Before production usage customer should refer to the latest datasheet for the updated specifications.
3. When using the products referenced in this document, please make sure the product is being operated within the environmental and electrical limits specified in the datasheet. If customer usage exceeds the specified limits, Kingbright will not be responsible for any subsequent issues.
4. The information in this document applies to typical usage in consumer electronics applications. If customer's application has special reliability requirements or have life-threatening liabilities, such as automotive or medical usage, please consult with Kingbright representative for further assistance.
5. The contents and information of this document may not be reproduced or re-transmitted without permission by Kingbright.
6. All design applications should refer to Kingbright application notes available at [http://www.kingbright.com/application\\_notes](http://www.kingbright.com/application_notes)